

---

# Dambo

SOFAS

2023

Piero Lissoni



## Description

---

Dambo is the third sofa system that Piero Lissoni has designed for B&B Italia. It's a modular system composed of irregular pentagons and rectangular modules that combines more complex geometric shapes with linear elements and lends itself to multiple compositions and environments. The pentagonal base elements, with their large dimensions and great flexibility, can be used as peninsulas when combined with other elements or as free-standing monoliths. They are cozy volumes to be placed in the middle of a room, to craft corner solutions or to create customized compositions. The high, enveloping backrests are a hymn to the organic forms of the botanical world. The armrests resemble petals thanks to a front movement that allows them to be lowered and adjusted as desired. There are five basic elements, characterized by a cozy softness and plush ergonomics. The different geometries are in harmony with each other, informal yet functional and versatile. The entire series boasts a cold-foamed construction system with state-of-the-art upholstery. Backrests and armrests are attached to the base structure by means of a bayonet coupling system. The small feet, with their discrete and essential design, have an elegant oval section. What emerges is lightness but also versatility, in line with the contemporary lifestyle dictates increasingly merging living spaces and home office corners. Dambo thus lends itself to a wide audience, faithful to the B&B Italia tradition, but with an eye on the art of modern living.

# Technical information

---

**Internal frame**

tubular steel and steel profiles

**Internal frame upholstery**

Bayfit® flexible cold shaped polyurethane foam, polyester fibre cover

**Cushions**

polyester fibre

**Feet**

die-cast aluminium

**Ferrules**

plastic material

**Cover**

fabric or leather

# Technical drawings

**DM218**

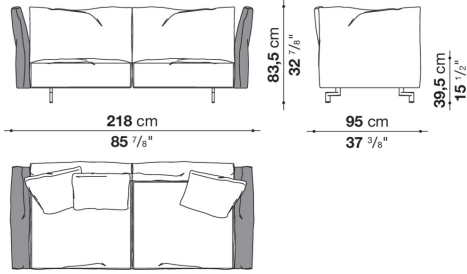

**DM312**

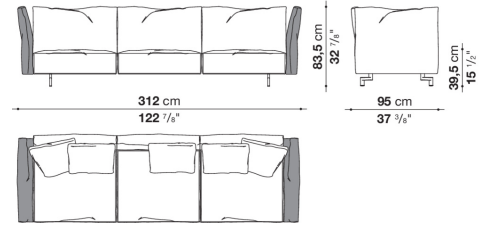

**DM92C**

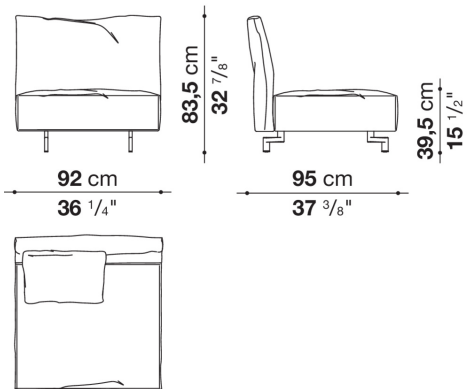

**DM186C**

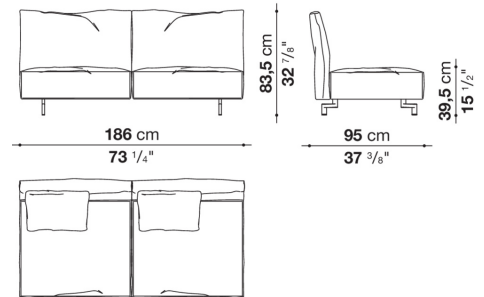

**DM280C**

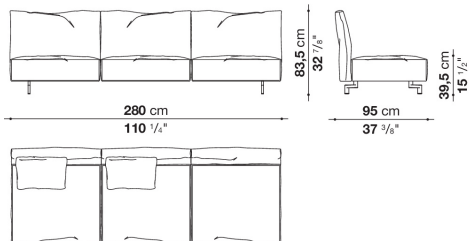

**DM108S**

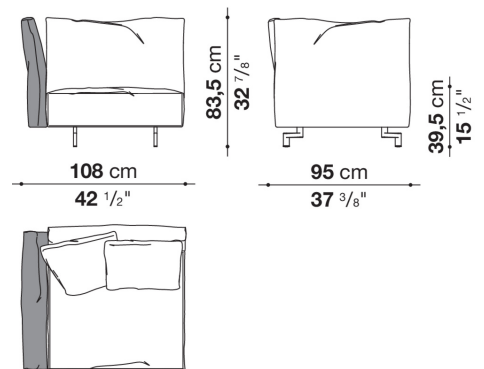

**DM108D**

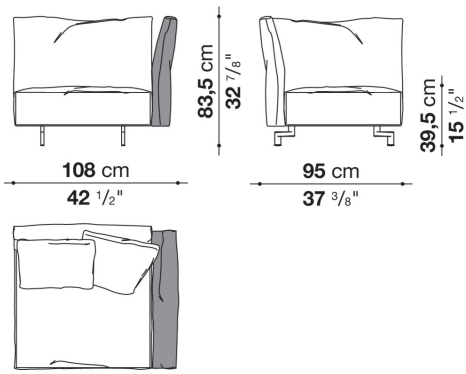

**DM202S**

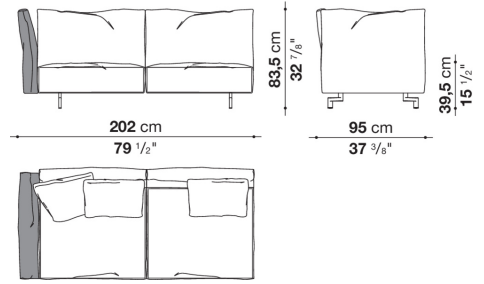

**DM202D**

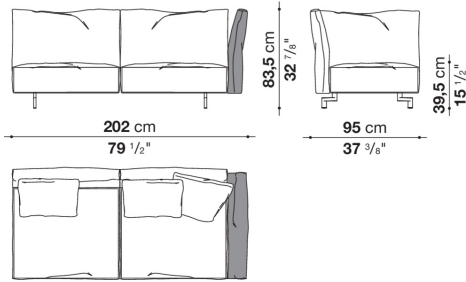

**DM296S**

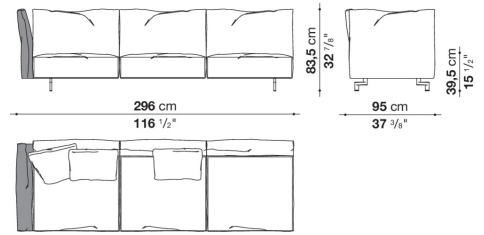

**DM296D**

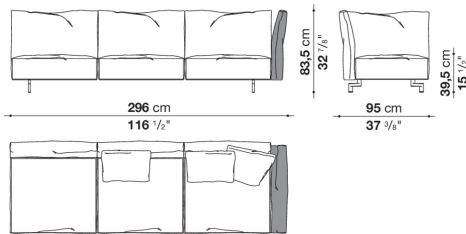

**DM108AS**

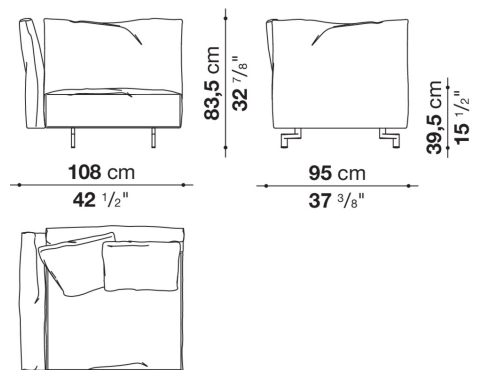

### DM108AD

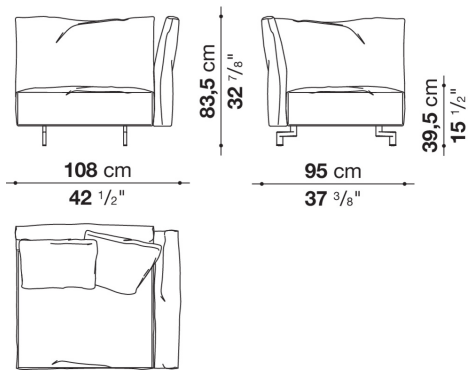

### DM218AS

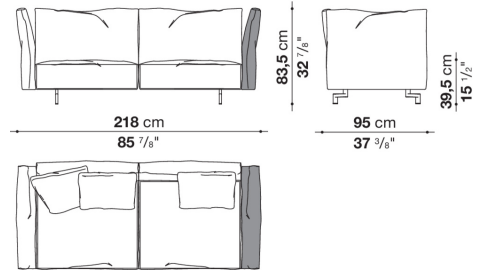

### DM218AD

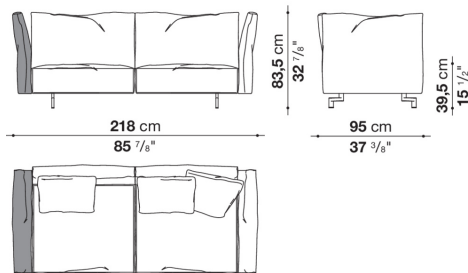

### DM312AS

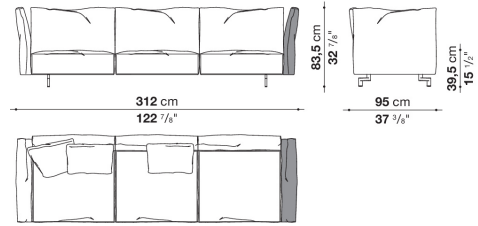

### DM312AD

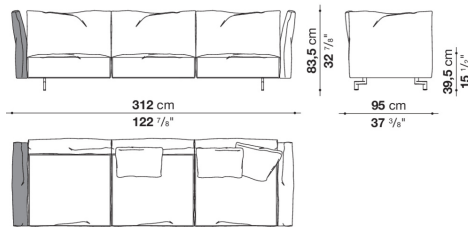

### DM154LS\_1

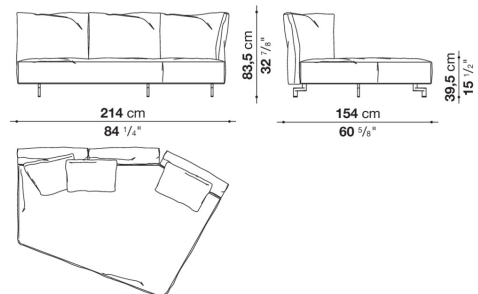

**DM154LD\_1**

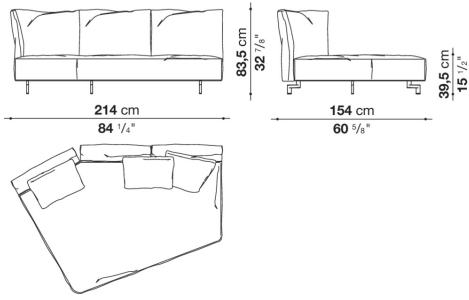

**DM154LS\_2**

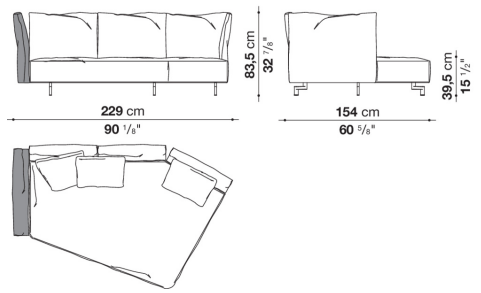

**DM154LD\_2**

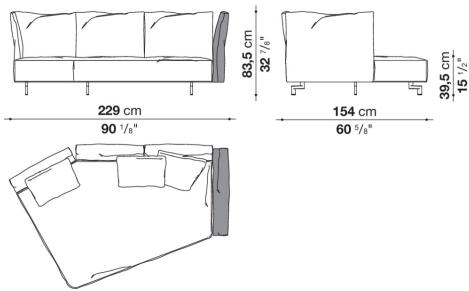

**DM178LS\_1**

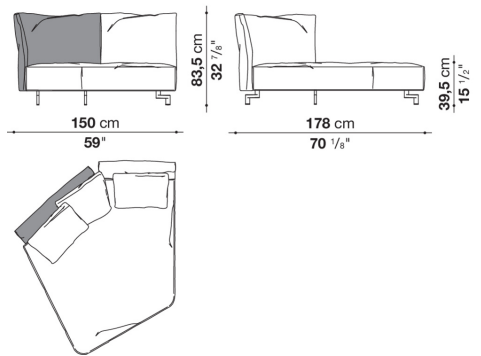

**DM178LD\_1**

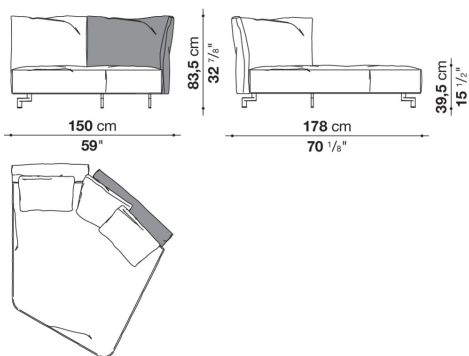

**DM178LS\_2**

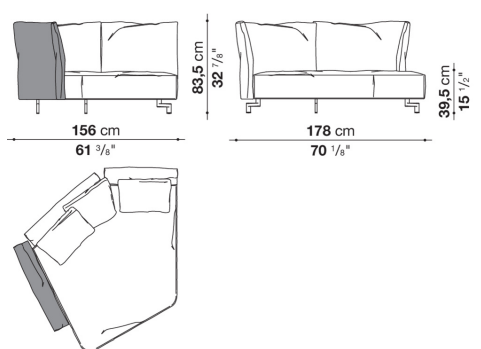

**DM178LD\_2**

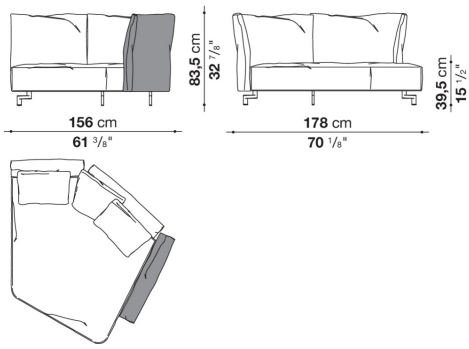

**DM92P**

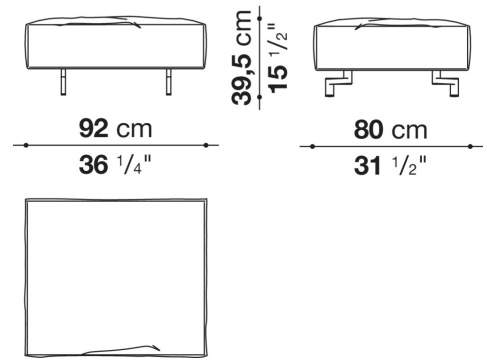

**DM186P**

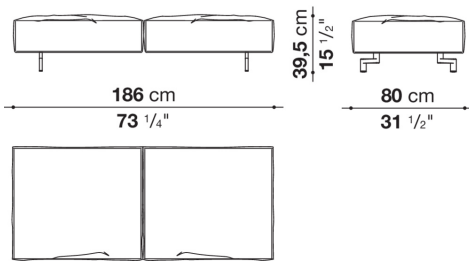

**DM280P**

